

2021-2022
2021-2022



CATALOGUE

Authorised dealer:

Website:



Contact details:



Copyright 2021 Machlab Scientific Sdn. Bhd. All Rights Reserved.
 Machlab Scientific Sdn. Bhd. has made every reasonable effort to
 present the contents of this catalogue accurately, but reserves the
 right to make changes to the information, product specifications and
 product range in this catalogue without prior notice.

Contents

Anti-Vibration Balance Table

Introduction	1
Features	1
Specifications	2
Products	3
Granite colours	3



INTRODUCTION

We offer rigid, stable surface developed specifically to help decrease vibration during measurement. When used in tandem with a weighing balance, the table allows the balance to perform with marked precision, despite air currents or movements that might cause readings to fluctuate.

Anti-Vibration Balance Table is designed for use in laboratory or metrology room to provide suitable working conditions for devices that are sensitive to vibrations and shocks.

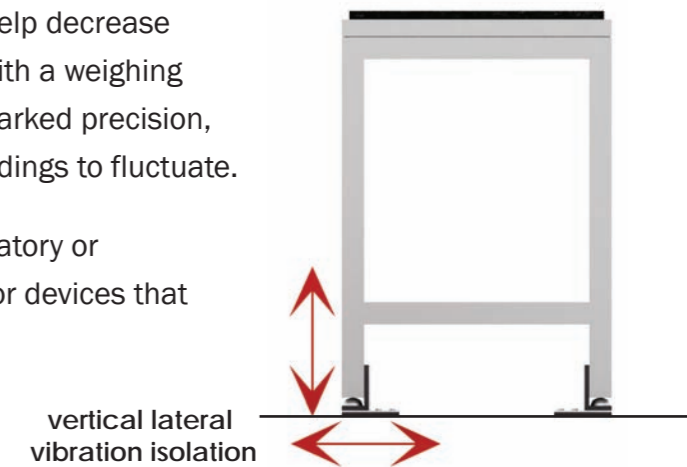

FEATURES

- Excellent acid, alkali and corrosion resistance performance.
- High temperature and impact resistance.
- Can be installed as stand alone or integrated with work benches.
- Easy to clean and maintenance-free.
- Eco-friendly and space-saving.
- Users can work in an ergonomic way at the balance table whether in standing or seated position.
- Can reduce shock when using precision testing equipment and other laboratory balances.
- Rigid construction and high quality materials for easy working.



We are a long established manufacturer and have a great deal of experience in the technical furniture industry.

For additional information, visit our website at www.machlab.com.my or contact us.

SPECIFICATIONS

① Granite top

Massive and durable Solid Granite Worktop is mounted on a supporting construction.

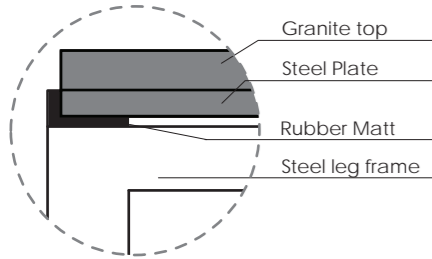

② Rubber damper

Installed around and under the worktop as dampers to reduce vibration.

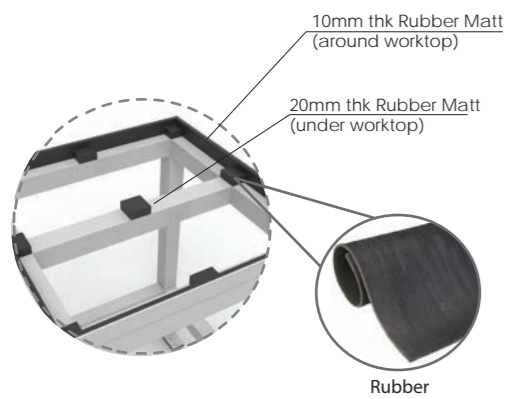

③ Steel frame leg

SHS 50x50 mm with Epoxy Powder Coating Finish

④ Bracket

- Maintains fixed table position to increase stability. Attached with durable industrial glides.

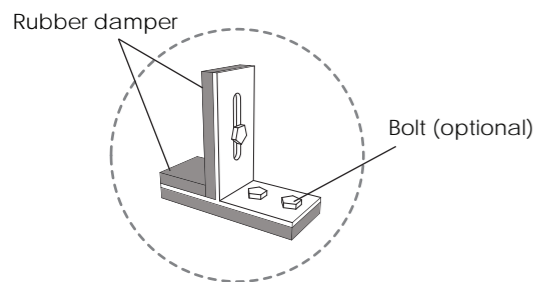

Design details

- Thickness of granite table top is 38 mm.
- Steel frame leg fabricated with **SHS 50x50 mm, epoxy powder coated.
- Steel lateral support beam adds strength and rigidity.
- Bracket comes with horizontal and vertical dampers to eliminate vibration transmission.

**SHS 50x50 mm steel frame leg is for all models except 900L and 1200L. For 900L and 1200L the size of the frame leg is SHS 65x65 mm.

PRODUCTS

450L

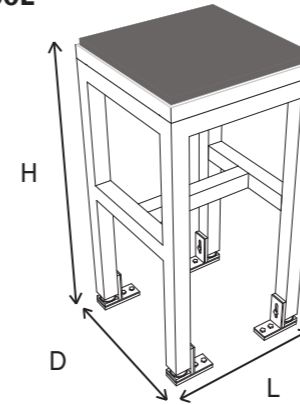

Size mm (L x D x H)	Code
450 x 450 x 900	BT-45-01

750L

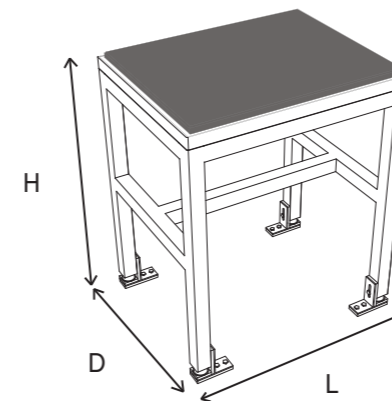

Size mm (L x D x H)	Code
750 x 450 x 900	BT-75-01
750 x 600 x 900	BT-75-02

1200L

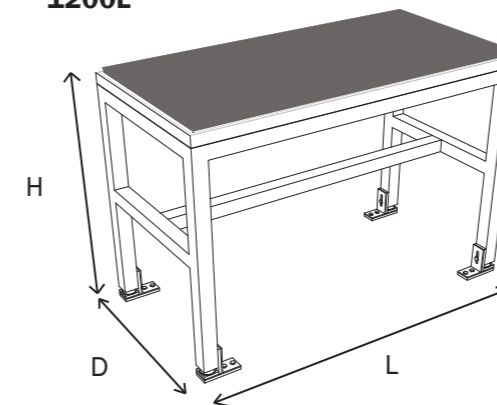

Size mm (L x D x H)	Code
1200 x 450 x 900	BT-120-01
1200 x 600 x 900	BT-120-02

600L

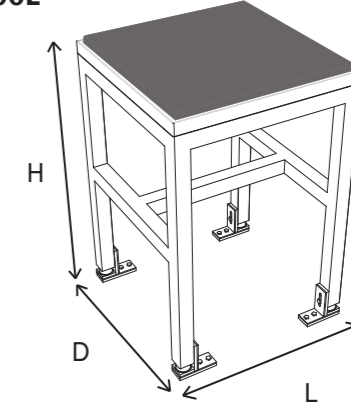

Size mm (L x D x H)	Code
600 x 450 x 900	BT-60-01
600 x 600 x 900	BT-60-02

900L

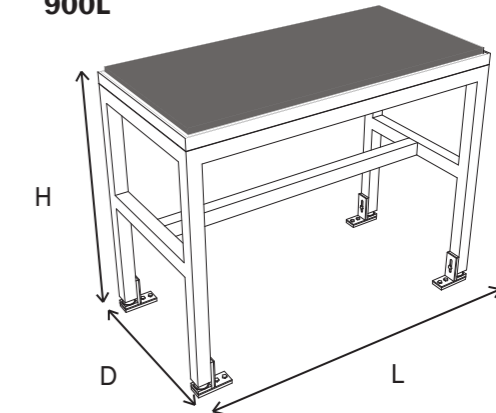

Size mm (L x D x H)	Code
900 x 450 x 900	BT-90-01
900 x 600 x 900	BT-90-02

GRANITE COLOURS

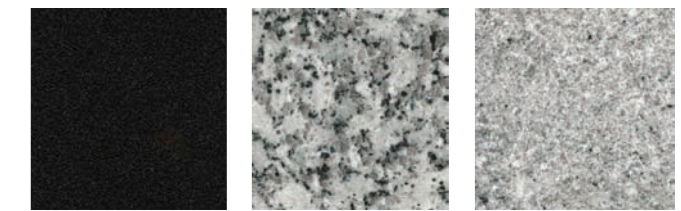

Absolute Black Platinum White Viscone White

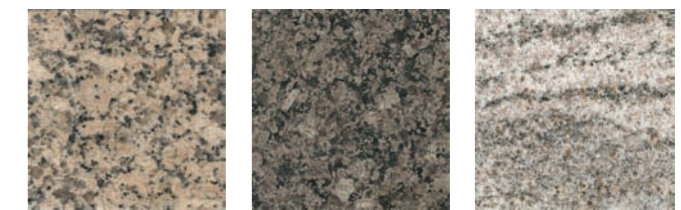

Crystal Yellow Nova Brown Golden River